

IP WatchDog Lite

Independent dual monitoring of Ethernet devices

IP WatchDog Lite monitors functionality of Ethernet devices. IP WatchDog Lite detects the devices' function by PING. If there is no response within a specified time period, IP WatchDog Lite will RESET the device (or switch to a back-up communication system, activate an alarm etc.)

Typical applications represent independent monitoring of the servers' function, network connection, microwave connection, IP cameras and similar devices.



Application examples

The IP WatchDog Lite, as a fully independent device, it's designed for monitoring or restart of the network devices or infrastructure. It's popular in metropolitan networks like WiFi APs or routers independent function control.

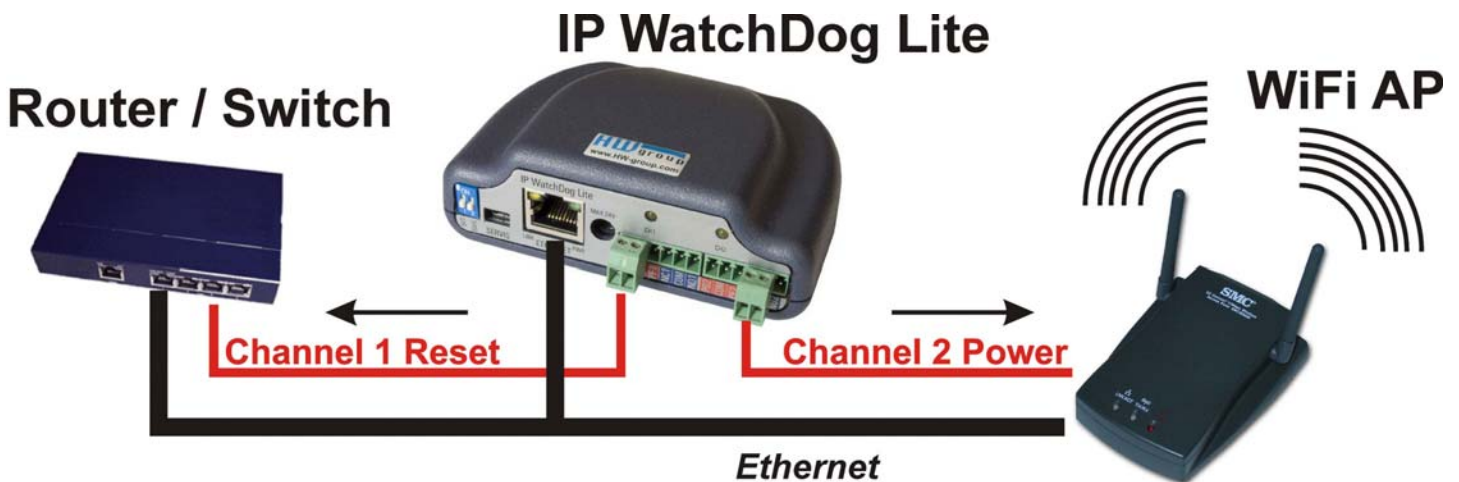

Two independent channels can be used individually for controlling or monitoring of different devices.

- Server and router monitoring and reset;
- Monitoring of a network infrastructure;
- ADSL and cable modem monitoring;
- WIFI AP monitoring, reset and restart;
- Security and access systems;
- Activation of backup connection in case of network connectivity dropout.

Methods of device monitoring

- **Outgoing PING**
IP WatchDog Lite is periodically sending PINGs to the defined IP Address (or at an alternative IP). If there is no response in the defined time, device will consider this as a fault and switch the relay.
- **Incoming PING**
IP WatchDog Lite is waiting for the incoming PING (ICMP). It is possible to define an IP address or range of addresses from which the PING is expected. If there is no PING received in defined time, IP WatchDog Lite switch the relay.

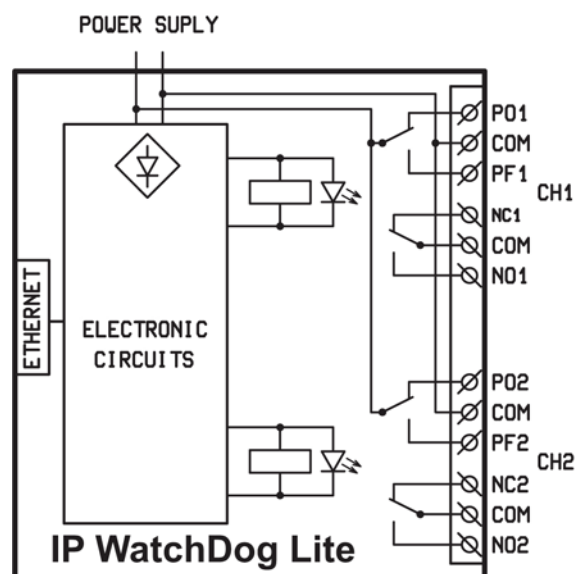

Basic Features

- **Ethernet** - RJ45 (10BASE-T - IEEE 802.3).
- **Two independent channels** (relays) for **reset / shutdown / startup**.
- **Device configuration via WWW pages**.
- **Device logfile** – accessible over WWW and XML
- **Time synchronization** from internet / intranet using TIME, NTP/SNTP or DayTime protocols.
- **FirmWare Update** is possible via WWW interface.
- **Easy channel configuration**
Choosing the connector's position it is possible to select one of the 4 channel types:
 - **NO** - Normally Open (relay contact)
 - **NC** - Normally Close (relay contact)
 - **PO** - Normally Power On (Output for direct power supply)
 - **PF** - Normally Power Off (Output for direct power supply)
- **Manual device control** (startup / shutdown / restart). Possible password protection.
- **Software support:** SDK and wide range of examples and for Windows and Unix/Linux.
- **Security** guaranteed using passwords and range of allowed IP addresses.
- Power supply: 9-24 V AC/DC
- Dimensions: 25 x 82 x 90 [mm].

IP-WatchDog

